

Quantum Flex™ Markers

P.O. Box 2848 • Anaheim, 92804 • 714-563-9749 • 714-776-6208 -FAX

Flexible Composite Utility Markers



Reduce your exposure to accidental dig-ins and service interruptions. Flexible, fiberglass reinforced composite markers from QMG protect your valuable underground investment by clearly and quickly identifying buried pipelines, valves, cables and other underground utilities. The unique design and composition of the Quantum Marker allows for substantial field abuse. Quantum flexible markers are designed to withstand vehicle impacts, livestock contact & vandalism in virtually all weather conditions. Several different marker styles to choose from, each marker style has a unique profile that combines strength and rigidity for ease of installation, with flexible characteristics that allow for lower maintenance and longer life.

Features & Benefits

Quantum markers are constructed from a fiberglass reinforced composite which is ultraviolet resistant and temperature stable. - Unlike thermoplastic markers, they will not soften when exposed to heat or embrittle in cold temperatures.

Solid color impregnated throughout the marker. Never needs painting. Will not fade and crack like thermoplastic or rust or rot like metal or wood.

Strong lightweight fiberglass reinforced composite material is 75% lighter than steel and 10 times stronger than typical thermoplastic. Lower transportation and storage cost at the jobsite.

Fire resistant characteristics of the material withstands small grass fires and controlled ditch burns. - Will not soften and melt like plastic markers.

Available in a variety of colors and sizes to meet your requirements. Custom or generic warning message, reflective sheeting or letters & numbers are available.



Installs in less than 60 seconds using a standard lightweight hand tool.



Flexible markers can be driven over with vehicles, flexing upon impact and returning upright.



Versatile applications include 9-1-1 rural address markers and campsite identification.

QM - 375 Specifications

Material: Glass Reinforced Polyester Composite
 Weight: 0.62 lbs per foot
 *Standard Lengths: 62, 66, 72, 78, 84 & 90 inch
 Width: 3 15/16 inch
 * Standard Colors: White, Orange, Yellow, Blue, Green, Red & Brown

A high performance marker designed for most utility identification applications. Offers the best choice for overall visibility and flexibility. The unique symmetrical design combines the strength and installation characteristics of standard flat markers, with the lower bending radius associated with curved type markers.

EASY INSTALLATION

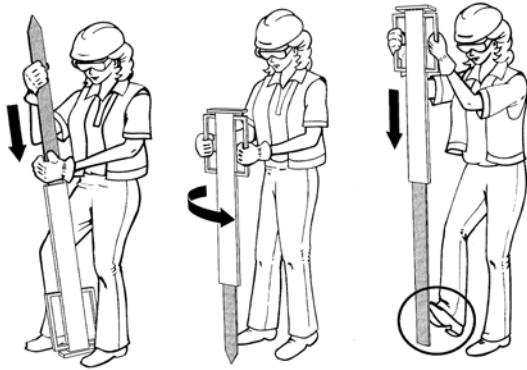

Installation is easy as 1, 2, 3!

1. Insert marker into driver.
2. Rotate driver with marker into position.
3. Drive marker with a series of light taps.
 (Brace your foot against marker to stabilize during installation)

QM - 250 Specifications

Material: Glass Reinforced Polyester Composite
 Weight: 0.31 lbs per foot
 *Standard Lengths: 62, 66, 72, 78, 84 & 90 inch
 Width: 2.5 in.
 *Standard Colors: White, Orange

An economical marker designed for applications where less flexibility and a lower profile is preferred. Dual rib design increases stiffness & improves installation. A good choice for survey and boundary identification where increased flexibility is not a concern.

* Custom colors or lengths available upon request

Distributed By:

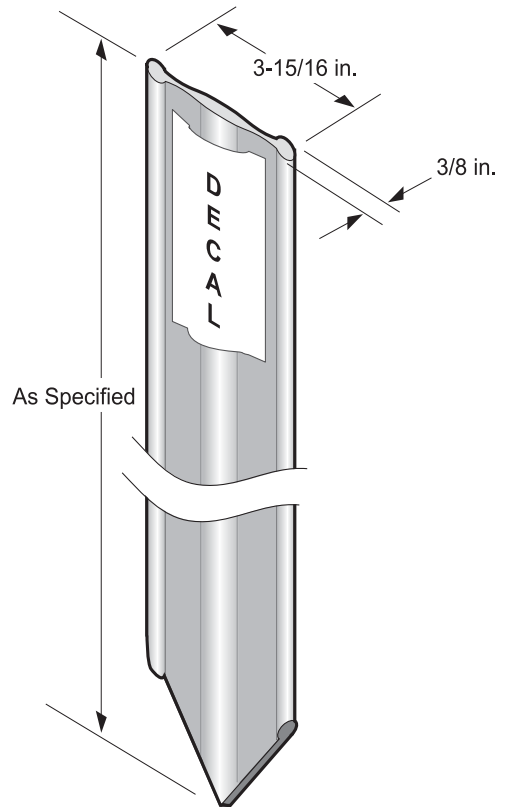

The symmetrical three rib profile optimizes rigidity, stability and flexibility. This provides an unobstructed recessed message area on both sides of the marker, offering protection of the warning message.

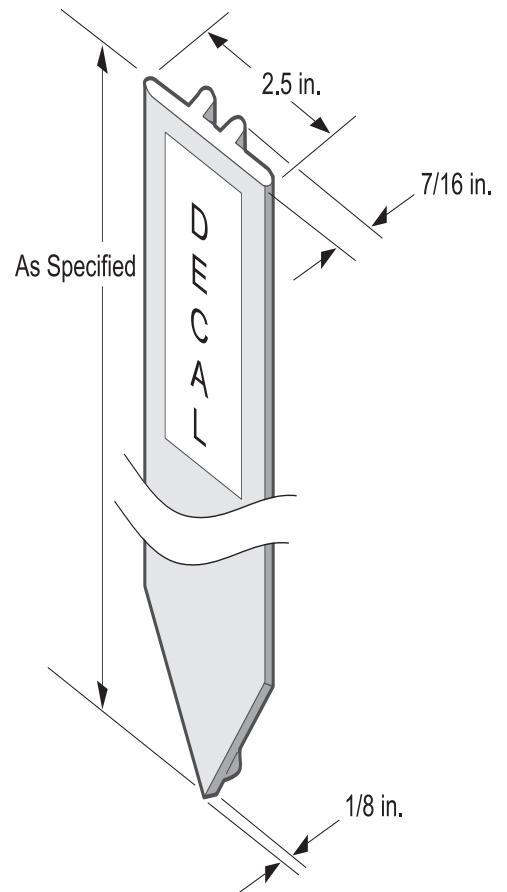

The dual rib profile optimizes rigidity & stability while still maintaining a degree of flexibility. This design provides for easy center drilling & attachment of optional signs and hardware.